

# NVE

National Vacuum Equipment

## NVE Challenger™ Series

Fan-Cooled

Liquid-Cooled

Packages

Heavy-duty vacuum pumps designed for extended use in liquid waste pumping systems.

### 367 Challenger™

*Made in the USA*



Truck Center of Fort Worth, Inc.  
2901 North Freeway  
Fort Worth, Texas 76106  
817-624-3181 800-709-3184

[WWW.FORTWORTHTRUCK.COM](http://WWW.FORTWORTHTRUCK.COM)

## NVE Challenger™ Series – Fan-Cooled or Liquid-Cooled

Our Challenger™ Series pumps are designed and built with the customer in mind – resulting in dependable, high performing pumps that are easy to install, operate and service.

- Superior cooling for extended operations in severe conditions
- Heavy duty roller bearings
- Slotted end plate bolt holes for crash protection
- Precision-pinned end plates
- 3-point oiling system
- Vane wear inspection port
- Exhaust gas temperature gauge
- Diesel flush port
- High-strength ductile iron housing
- Air-injected ballast port cooling for extended use in deep vacuum (506)



### 367 Challenger™

Dimensions: 13 1/2" W x 31 5/8" L x 24 1/16" H

Weight: 470 Lbs.

Available in liquid-cooled and fan-cooled.

**Recommended Setup for Optimum performance**

RPM		Pressure (PSI)					Free flow		Vacuum (inches of Mercury)					
		20	15	10	5	0	5	10	15	20	25	27		
1500	Hp.	34	32	29	27	23	23	22	21	20	19	19		
	CFM	282	291	301	331	357	248	338	331	310	282	244		
1250	Hp.	29	27	24	23	20	20	19	16	15	14	14		
	CFM	229	237	244	269	290	282	275	269	252	229	198		
1000	Hp.	25	23	20	18	15	15	14	14	13	12	12		
	CFM	178	184	190	209	226	220	214	209	196	178	155		

1500 RPM Intermittent Operation only



### 506 Challenger™

Dimensions: 17 1/16" W x 30 1/16" L x 24 5/8" H

Weight: 515 Lbs.

Available in liquid-cooled and fan-cooled.

RPM		Pressure (PSI)					Free flow			Vacuum (inches of Mercury)						
		25	20	15	10	5	0	3	6	9	12	15	18	21	24	27
1150	Hp.	49	43	36	27	25	18	20	21	22	23	24	25	25	28	29
	CFM	408	431	438	447	457	519	500	470	458	453	440	438	425	404	351
1000	Hp.	43	38	32	24	20	15	17	18	19	20	21	22	23	24	25
	CFM	355	375	381	389	398	452	435	409	399	394	390	381	370	352	306
800	Hp.	36	32	25	19	15	13	14	14	15	16	17	18	19	20	21
	CFM	302	319	324	331	342	385	374	348	339	333	331	324	315	303	242

1150 RPM Intermittent Operation only

## NVE Challenger™ Series Packages

NVE pioneered pump packages, and our engineering department continues to lead the industry in design and fabrication. We offer the most complete, easy to install packages available – allowing you to significantly reduce your engineering and installation time.

*Packages are available in a variety of different setups including clockwise (CW) and counter-clockwise (CCW) rotations.*

### Standard Mounting Package

**Pallet weight: 564 Lbs.**

- Rugged, 3/8" construction, powder coat painted pump bracket
- Easy-align, adjustable gear box bracket
- 400 series three-shaft gear box accommodates CW and CCW rotation
- Coupler set with shear protection



### 367 and 506 Muffler Package

**Pallet weight: 367 - 805 Lbs.; 506 - 897 Lbs.**

All the features included in the Standard Mounting Package, plus:

- Compact designed square oil catch muffler
  - Effective baffle system
  - Stainless steel mesh filter
  - Drain valve
  - Exhaust deflector (other exhaust fittings available)
- All elbows, fittings and high temp hose are factory connected
- Right-hand or left-hand muffler location available



### 367 and 506 Max Pack

**Pallet weight: 367 - 847 Lbs.; 506-999 Lbs.**

All the features included in the Muffler Package, plus:

- High efficiency aluminum moisture trap
  - Accessible 6" stainless steel float ball
  - BUNA positive shut-off ball seat
  - 2" lever drain valve
  - Blind intake flange standard (other fittings available)
- Vacuum/pressure relief valves and gauge



### Self Contained Engine Drive Packages

**Pallet weight: 367 - 1297 Lbs.**

- Rugged, low-profile frame for belly-mount applications
- Deutz power unit with tachometer and LOFA control panel
- 23 gallon fuel tank
- High efficiency oil catch muffler
- Vacuum pressure relief manifold and gauge
- Powder coat painted and factory assembled



### Hydraulic Motor Drives

- Heavy-duty two or four-bolt SAE flanged bracket
- Coupler set with automatic alignment
- Properly sized hydraulic motor



# NVE Challenger™ Series Package Selection Guide

NVE makes it easy to select the pump package that is right for you. Choose from one of the setups shown, or contact our knowledgeable sales staff at 800-253-5500 or sales@nvepump.com.

367 CW "Max Pack" Assembly  
F-1000-2MTCW

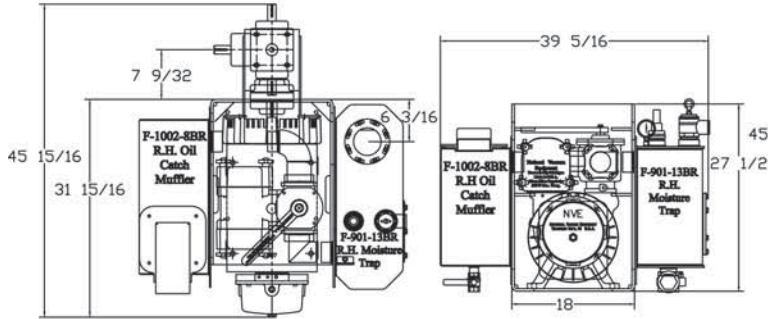

367 CW "Muffler Pack" Assembly  
F-1000-2MCW

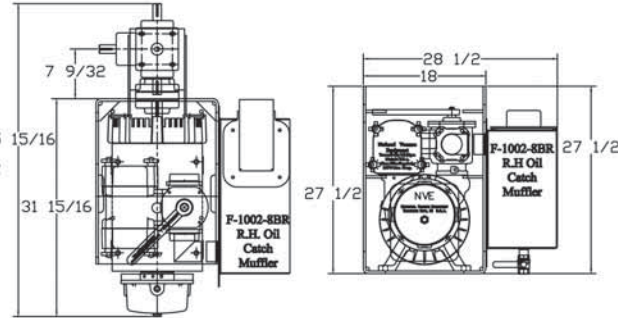

367 CCW "Max Pack" Assembly  
F-1000-2MTCCW

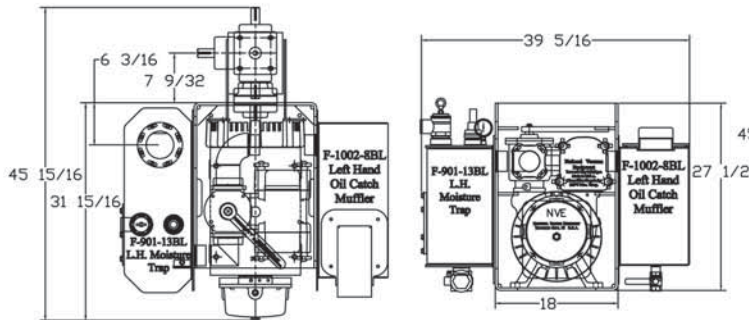

367 CCW "Muffler Pack" Assembly  
F-1000-2MCCW

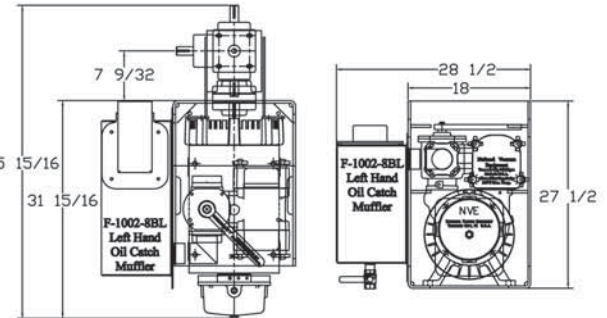

506 CW "Max Pack" Assembly  
F-1000-3MTCW

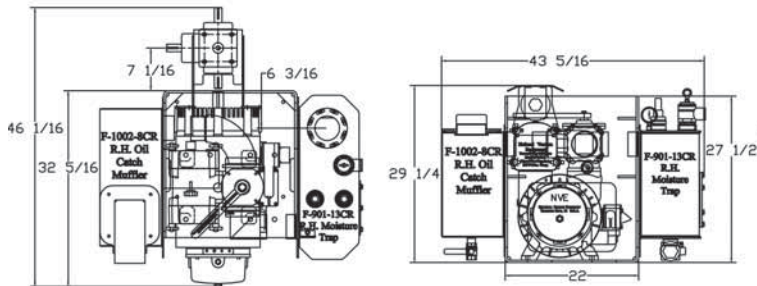

506 CW "Muffler Pack" Assembly  
F-1000-3MCW

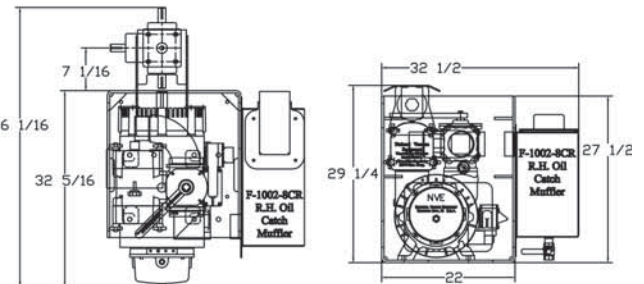

506 CCW "Max Pack" Assembly  
F-1000-3MTCCW

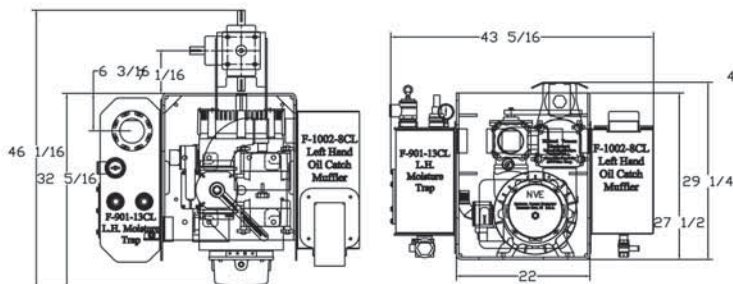

506 CCW "Muffler Pack" Assembly  
F-1000-3MCCW

