

## Onspot Chain Unit Mounting Instructions

1. Install mounting brackets per the BRACKET MOUNTING INSTRUCTIONS provided with the brackets. Make sure the vehicle's U-Bolt nuts and adapter nuts are torqued to MANUFACTURER'S specifications.
2. Using the two supplied 5/8" Grade 8 bolts, flat washers, and Top Lock® nuts mount the ONSPOT chain unit to the mounting bracket as indicated on the *Bracket Mounting Document*. The mounting bolts should be left loose at this time so adjustments can be made later.
3. Install the chainwheels. Install the helmet between the bottom of the arm and top of the wheel. See Fig. 4 for exact method depending on which chainwheel bolt your model has. Make sure the arm passes through the two uprights on the chainwheel helmet.  
NOTE: The **RED** chainwheel is for the **LEFT** (driver side); the **BLUE** chainwheel is for the **RIGHT** (passenger side) of the vehicle.
4. Using compressed air approx. 100-psi (controlled by a ball valve) engage the chain unit so the chainwheel contacts the tire. Check for any interference. **Release the air pressure SLOWLY or the chains will retract very quickly.**

The chainwheel should contact the tire as follows:

- a. Chainwheel should contact the tire at the **VERTICAL CENTERLINE of the tire.** (ref Fig. 1)
- b. The **PITCH** of the chainwheel should be **0** to **-1** degree (ref Fig. 1)  
  
**NOTE:** Onspot offers a part number 9013 angle gauge to assist in measuring pitch and operating angle.
- c. **OPERATING ANGLE** of chainwheel should be **8** to **15** degrees (ref Fig. 2)
- d. Vertical distance from the ground to the chainwheel contact point should be approx. 3 ½" to 4" with the vehicle unloaded (chassis with no body should be 4 ½". 3" min with the vehicle loaded) (ref Fig 2).
- e. On ambulances and vehicles with small tires (16" or smaller) the chainwheel should contact the bulge of the tire (approx. 2 5/8" from the ground).

Adjustments to chainwheel height may be made via the chainwheel spacers (ref Fig. 4). Additional adjustments may be made by moving the mounting brackets. Please contact ONSPOT if necessary for additional adjustment guidance.

**NOTE:** If your Onspot chain set uses the adjustable chainwheel bolt see the included sheet *Adjustable Chainwheel Instructions* for proper assembly.

5. The **MINIMUM** distance from the tire sidewall to the mounting bracket is 1/2".  
The **MINIMUM** distance from the chainwheel to the drive shaft is 3/8".
6. Once the chainwheel is correctly positioned and there is no interference, **torque the chain unit mounting bolts to 125 Ft - lbs, and the chainwheel bolt to 125 Ft - lbs.**

**NOTE: DO NOT USE AIR TOOLS** to tighten the chain unit mounting bolts as over torquing these bolts will cause premature failure. **PLEASE** use a TORQUE WRENCH.

7. Install the electric toggle switch in the cab of the vehicle. Connect the switch to a fused 12- volt power "key on" source (powered through the ignition switch). The proper wiring of the ONSPOT switch is as follows:

F - terminal - Positive (power)  
O - terminal - Positive (power)  
D - terminal - Solenoid valve  
F - terminal - Negative (ground)  
(See illustration of 9004 Switch)

When the switch is wired correctly, it will glow white any time the ignition switch is in the ON position. When the ONSPOT switch is in the ON position, the switch color will change to RED.

**NOTE:** An existing switch in the vehicle may be used, but we recommend a switch guard be used.

8. Choose a protected area close to the chain units to mount the air / electric solenoid. Remove any undercoating or protective coating, which may inhibit proper grounding of the solenoid. As with any electrical component, subjecting it to a harsh environment may shorten its life. Consider mounting the solenoid in the cab or under the hood.

**NOTE:** The solenoid is grounded through the mounting bracket. Mount the solenoid in the **VERTICAL** position. Connect the solenoid to the electric switch (ref. Fig.3)

**NOTE:** If the application is a school bus, consult the vehicle Body Builder manual for proper procedure connecting into the vehicle's air and electrical systems. Consult the dealer where the bus was purchased or Onspot.

9. A “pressure protection valve” **MUST** be used at the air source on vehicles with air brakes. This valve will prevent a complete loss of air from the air source should an ONSPOT air line leak or break. There may already be a protected air source on the vehicle for accessories (check with body builder book or the (dealer). **The air source should never be taken from the foot valve, drain cock, or treadle valve.** A PPV is available separately as Part # 9007, please contact ONSPOT for more details.

10. Install the air lines and fittings provided. The line from the air source must be connected to the TOP of the solenoid valve using one of the 90 deg fittings provided. Use the “Tee” fitting on the FRONT (outlet) hole from the solenoid valve. Connect an air line from each of the two chain units to this tee fitting. (ref. Fig.3)

Slide the protective tubing over the air lines where chassis contact may occur. Place the sticker labeled “*Operating Instructions*” on the dashboard in plain sight of the operator.

11. Once the installation is complete engage the chain units and (using a fish scale) pull the chainwheel away from the tire. This should require at least 20 lbs. of effort.

12. We recommend the Onspot system be checked via a road test in forward and reverse. Engage and disengage the chains while the vehicle is MOVING between 3 and 5 MPH. Refer to the *Operation and Maintenance* card.

**\* \* \* CAUTION \* \* \***

Due to high spring tension, **DISASSEMBLY / ASSEMBLY** of the air cylinder should be done only by qualified personnel.

Chain units may be mounted in front of or behind the rear axle depending on application. Refer to Bracket Mounting Document

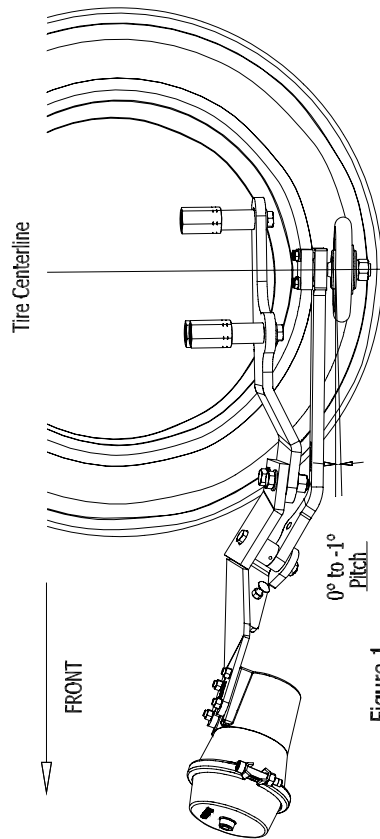

Figure 1

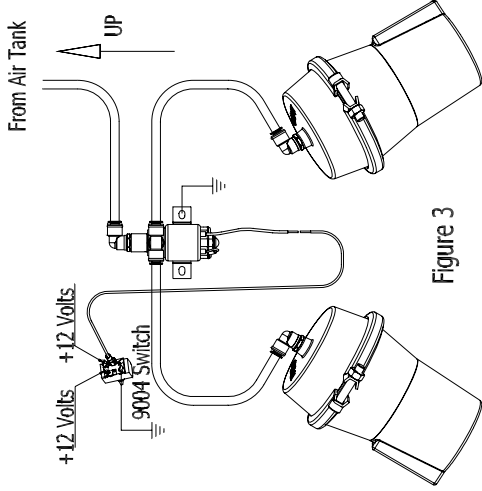

Figure 3

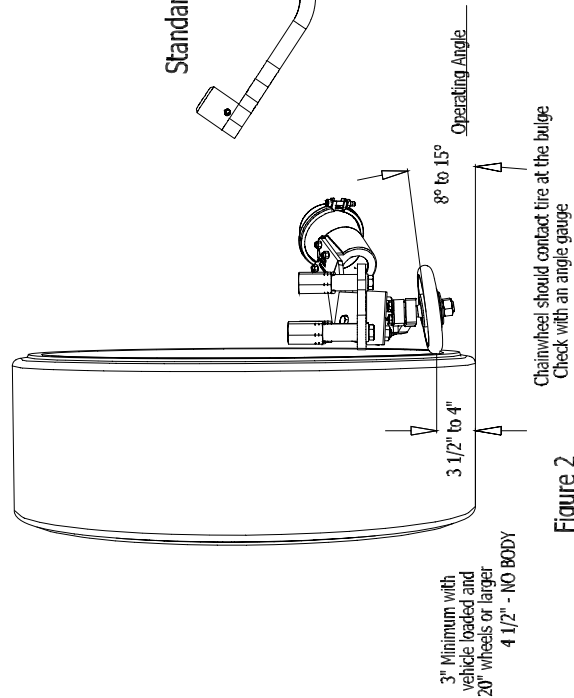

Figure 2

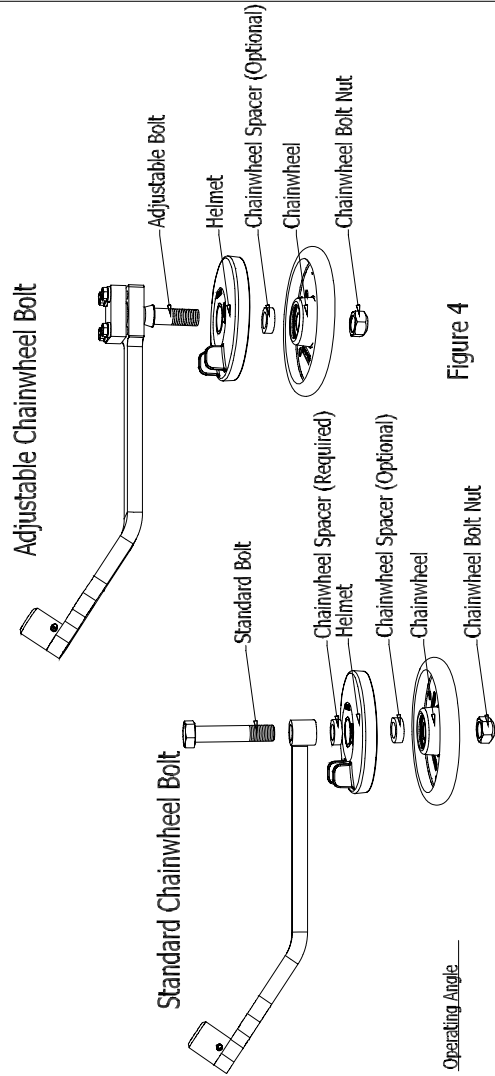
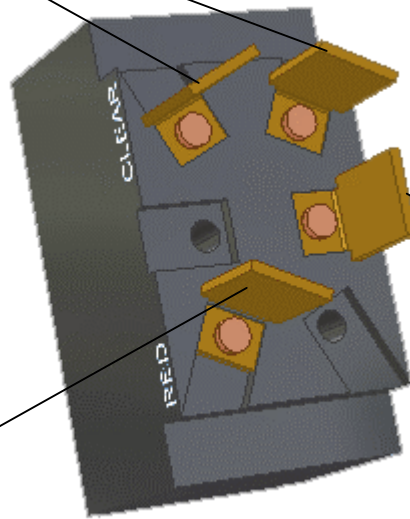

Figure 4

## 9004 Dash Switch

12 Volts

Ground



Solenoid