

12FT

PRO SERIES TILT BED EQUIPMENT TRAILER

G.V.W.R.	12,000#	AXLES	Two 6000# EZ LUBE w/ Elec. Brakes
G.A.W.R. (Ea. Axle)	5,500#	SUSPENSION	Multi-Leaf Slipper Spring w/ Equalizer
COUPLER	2-5/16" Bulldog	TIRE	7.50 X 16" Load Range E
SAFETY CHAINS	3/4" Grd. 70 w/ Safety Latch Hook (2 ea.)	WHEEL	16 X 6 White Spoke 8 Bolt
JACK	2000# Top Wind, Bolted On	FLOOR	2" Pine
TONGUE	5" Channel Fold Back	LIGHTS	D.O.T Stop, Tail, Turn and Clearance
TOP RAIL	(none)	ELEC. PLUG	7-Way RV
FRAME	6" Channel	FINISH (PRER)	Acid Etched w/White Phosphorus, Undercoated w/Panther 813 & Two Coats Primer
CROSSMEMBERS	3" Channel + 3" Square Tube	FINISH	Painted w/ 2 Coats High Solid <i>Supreme Acrylic</i> Automotive Grade Enamel, and Pinstriped
UPRIGHTS	(none)		
FENDERS	10 3/4" X 72" Diamond Plate Teardrop w/		

- Lower Jack Support Plate
- Two 6,000# Axles w/ 2 Electric Brakes
- Complete Break-A-Way System w/ Charger
- 1/4" Diamond Plate Knife Edge
- Cambered Ez Lube Axles
- 102" Wide Overall, 80" width between the fenders
- 2-5/16" Bulldog Forged Coupler
- Safety Chains Attached w/ Cold Rolled Eyelets
- Tilt Platform is 75" Wide
- Floor Secured w/ 5/16" Tbrx Screws
- Spare Tire Mount
- Hydraulic Dampening System
- Unique Two Piece Main Frame
- Fold Back Tongue w/ Raised Coupler

12FT-16

LENGTH	DIMENSIONS			
	A	B	C	D
16'	202-1/2"	101-1/8"	101"	13"
18'	225-1/2"	112-1/2"	113"	12"
20'	249-1/2"	121-1/2"	128"	11"

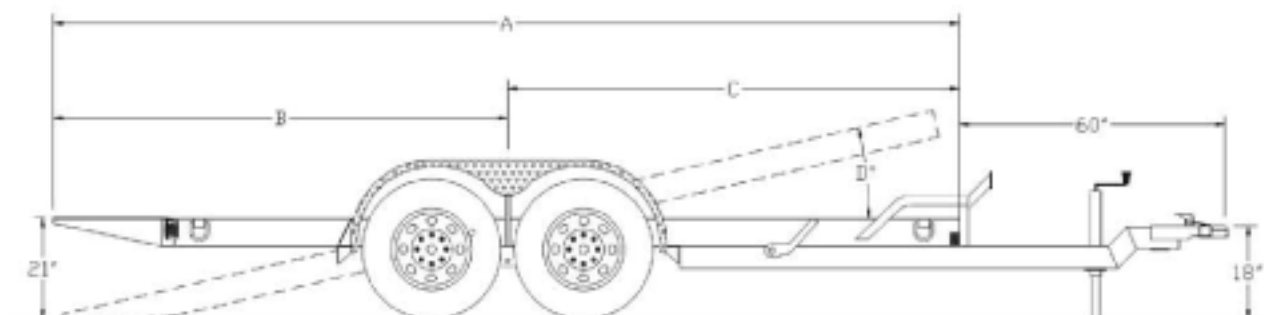

PRICING

MODEL #	WEIGHT	DESCRIPTION	PRICE
12FT-16	2575#	80" X 16' 12,000# Tilt Trailer	
12FT-18	2900#	80" X 18' 12,000# Tilt Trailer	
12FT-20	3225#	80" X 20' 12,000# Tilt Trailer	

OPTIONS

Hydraulic Brakes On 2 Axles w/ Adjustable Demco Actuator	
16" Spare Tire & Wheel	
7K Drop Leg Jack	
1/8" Diamond Plate Steel Floor (Per Sq. Ft.)	
Adjustable Coupler In Channel	
Extra 5/8" D-Rings (Each)	
ST235-85R16 Tire Upgrade	
ST235-85R16 Spare	

Prices Effective August 1, 2006

© 2006 Copyright by Big Tex Trailer Manufacturing, Inc.