

14CC

TANDEM AXLE EQUIPMENT TRAILER

G.V.W.R. 14,000#	AXLES Two 7000# EZ LUBE w/ Electric Brakes
G.A.W.R. (El. Axle) 7,000#	SUSPENSION Multi-Leaf Spring w/ Equalizer
COUPLER Adjustable 2-5/16"	TIRE ST235/85R-16 Load Range E
SAFETY CHAINS 3/8" Grd. 70 w/ Safety Latch Hook (2 ea.)	WHEEL 16 X 6 White Spoke 8 Bolt
JACK 10,000# Top Wind Drop Leg	FLOOR 2" Pine
TONGUE 6" Channel Fold-Back	LIGHTS D.O.T. Stop, Tail, Turn and Clearance
TOP RAIL (none)	ELEC. PLUG 7-Way RV
FRAME 6" Channel	FINISH (PREP) Acid Etched w/White Phosphorus, Undercoated w/Panther 813 & Two Coats Primer
CROSSMEMBERS 3" Channel	FINISH Painted w/2 Coats High Solid <i>Supreme</i> Acrylic Automotive Grade Enamel, and Pinstriped
UPRIGHTS (none)	
FENDERS 9" X 72" Diamond Plate w/ Back	

- Two 7000# Axles w/ Electric Brakes
- Complete Break-A-Way System w/ Charger
- 2-5/16" Adjustable Coupler
- Cambered Ez Lube Axles
- Spare Mount
- Safety Chains Attached w/ Cold Rolled Eyelets
- Floor Secured w/ 5/16" Torx Screws
- 2" Tubular Stop Rail
- Reflective Marker Tape
- 5' Slide In Ramps (Channel)
- Tie Down Pockets - Sides & Rear
- Fold Back Tongue
- Rear Stabilizer Stands

14CC

<i>DIMENSIONS</i>			
LENGTH	A	B	C
16'	193-1/2"	78-1/2"	115"
18'	217-1/2"	90-1/2"	127"

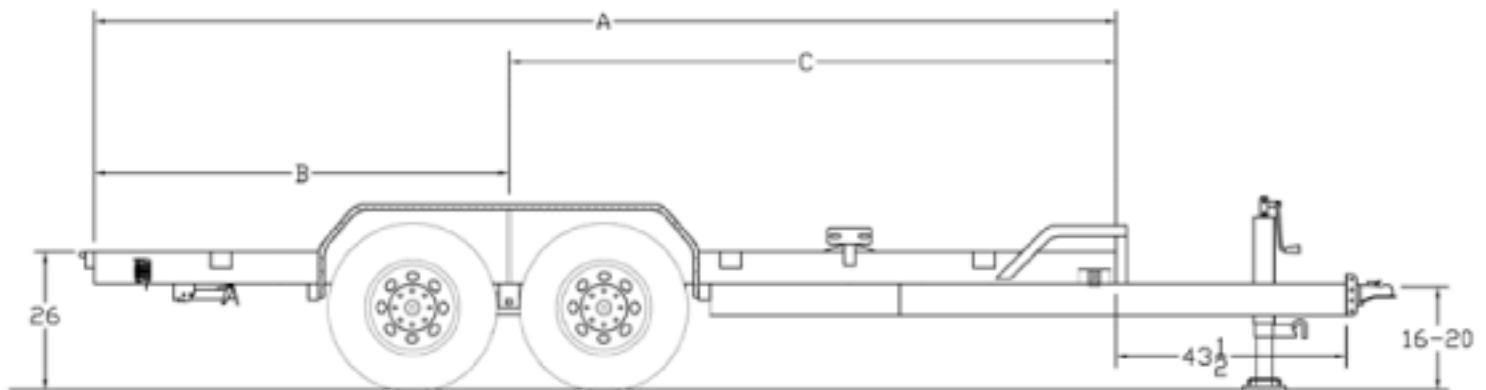

PRICING

MODEL #	WEIGHT	DESCRIPTION	PRICE
14CC-16	2560#	83" X 16' Tandem Axle Equipment Trailer	
14CC-18	2710#	83" X 18' Tandem Axle Equipment Trailer	

OPTIONS

16" Spare Tire & Wheel - Load Range E	
---------------------------------------	--

(STD. MODEL - NO OTHER OPTIONS AVAILABLE)